

71" FRAYSER CAST IRON DOUBLE-SLIPPER PEDESTAL TUB - ROLLED RIM

SKU: 946214-RR

Code: SH423062, SH474814, SH474815, SH474816, SH474820



FEATURES

Tub Material: Cast Iron

Product Finish: White

Shape: Oval

Tub Drain Placement: Offset

Drain Included: Optional

Water Depth to Overflow: 13-3/4"

Water Capacity (Gallons): 53

Built-In Adjusters: No

Tub Weight Uncrated (lbs): 580

Optional Accessory: 428473

ASME A112.18.2/CSA B125.2, ASME A112.19.1/CSA B45.2, LISTED ID: SH112162CICRR, 510720, 510721, 510724, 510729



ADDITIONAL FEATURES

- Overflow Drain will include: Extended Pop-Up Drain with Swivel Head, a Daisy Wheel overflow, which remain open to allow water into the drain.
- Requires a wall-mount or freestanding tub filler.

REVISED 6/28/2024

71" FRAYSER CAST IRON DOUBLE-SLIPPER PEDESTAL TUB - ROLLED RIM

SKU: 946214-RR

Code: SH423062, SH474814, SH474815, SH474816, SH474820

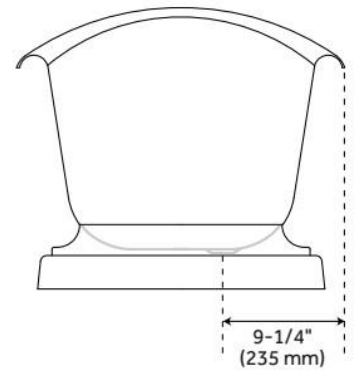
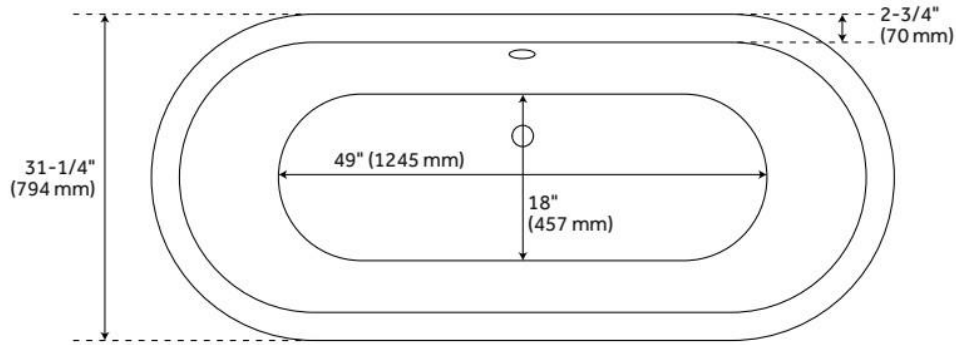
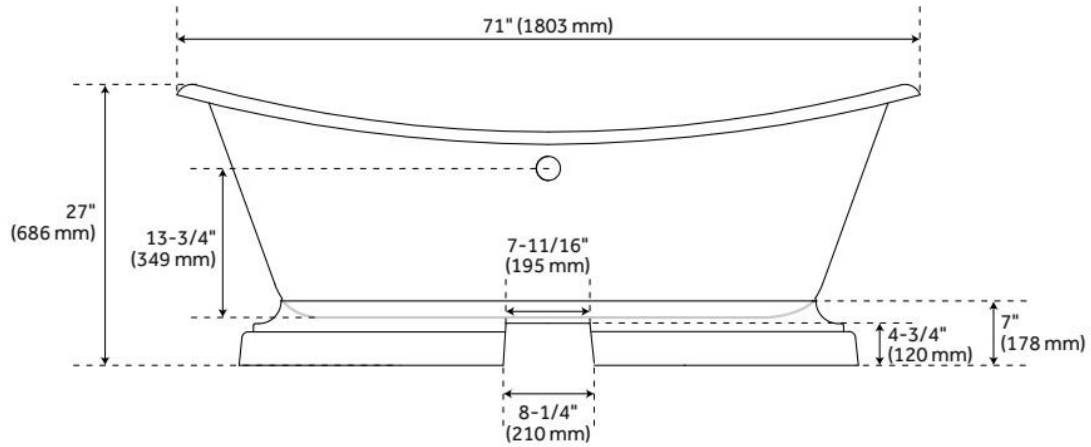

REVISED 6/28/2024