

CONCEALED IN-WALL TANK CARRIER FOR WALL MOUNT TOILET

SKU: 953818

Code: SH484123,SH484125,SH484126,SH484127



FEATURES

Product Finish: White

Material: Vitreous

China

Length: 19-1/2"

Height: 44-7/8"

Depth: 3-3/4"

Bowl Shape: Elongated

Gallons Per Flush: 1.6

ASME A112.19.2/CSA B45.1



REVISED 1/6/2023

CONCEALED IN-WALL TANK CARRIER FOR WALL MOUNT TOILET

SKU: 953818

Code: SH484123, SH484125, SH484126, SH484127



ADDITIONAL FEATURES

- Dual-flush toilet. 1.08 / 1.6 gallons per flush.
- Compatible with the Arnell Wall-Mount Toilet.
- Bowl Sold Separately.

REVISED 1/9/2023

ARNELLE CONCEALED IN-WALL TANK CARRIER

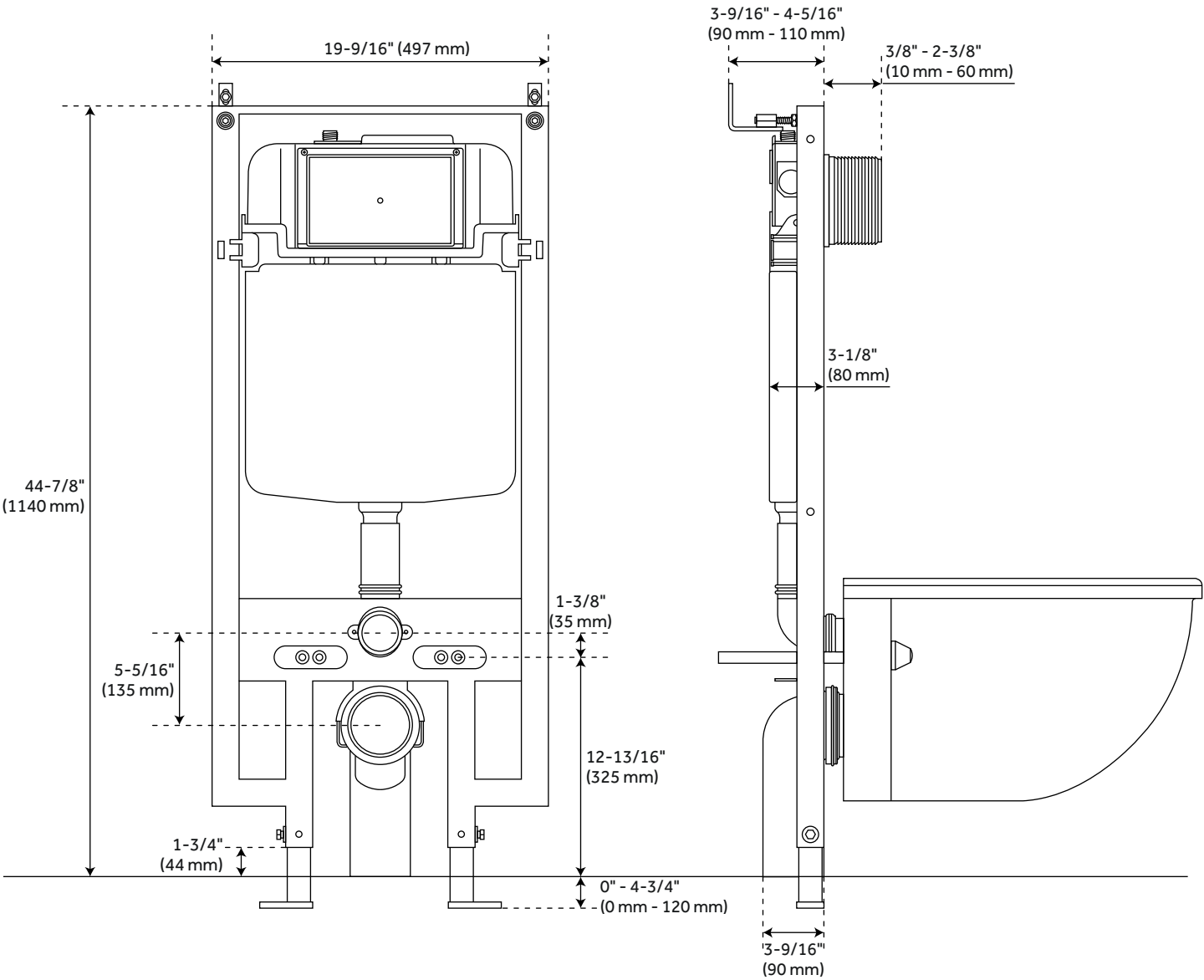

All dimensions and specifications are nominal and may vary. Use actual products for accuracy in critical situations.